

# PMB 6271

SMARTi SD2

CMOS GSM/GPRS Single Chip RF IC



SMARTi SD2 (PMB 6271) is a member of Infineon Technologies widely successful SMARTi family of single chip radio transceivers, and already the second one to benefit from CMOS technology. SMARTi SD2 is a quad-band (GSM850/900/1800/1900) single chip GSM/GPRS radio transceiver for worldwide roaming, optimized for cost, size and power consumption. SMARTi SD2 integrates into a single chip all functions required of the GSM radio of today and tomorrow. Through innovative transmit and receive architectures, SMARTi SD2 makes full use of CMOS technology to reach low radio system cost with long stand-by and talk time.

SMARTi SD2 is entirely controllable through a 3 wire bus. In combination with Infineon's E-GOLDlite and E-POWERlite a compact 3 chip system approach is achieved resulting in a very small and cost effective solution.

## Applications

- GSM/GPRS Dual-, Triple and Quad-Band Mobile Phones and Data Modems

## Features

- Full Quad-Band solutions for GSM850/900/1800/1900
- Fully integrated RF VCO @ 3.8 GHz
- Sigma-Delta Synthesizer provides Ultra Fast locking time for GPRS class 12 with integrated loop filter
- Multiplexed I/Q lines
- Direct Conversion Receiver with integrated blocking filters
- Integrated balanced LNAs for GSM850/900/1800/1900
- Programmable DC output level
- 3 wire bus
- Digital Sigma-Delta Modulator
- Integrated DCXO, only one external XTAL needed
- Ultra low power consumption
- Ultra Low RF BOM: <20 components needed

## Technology

- Based on Infineon's proven C11 0.13  $\mu\text{m}$  CMOS Technology
- Supply Voltage 1.5 V and 2.5 V
- P-VQFN-32 Package (5.5 x 4.5 mm<sup>2</sup>)

[www.infineon.com/mobilesolutions](http://www.infineon.com/mobilesolutions)

## Mobile Solutions



Never stop thinking.

## Infinion GSM/GPRS Quad-Band Solution Using SMARTi SD2 (PMB 6271), E-GOLDlite (PMB 7860) and E-POWERlite (PMB 6814)

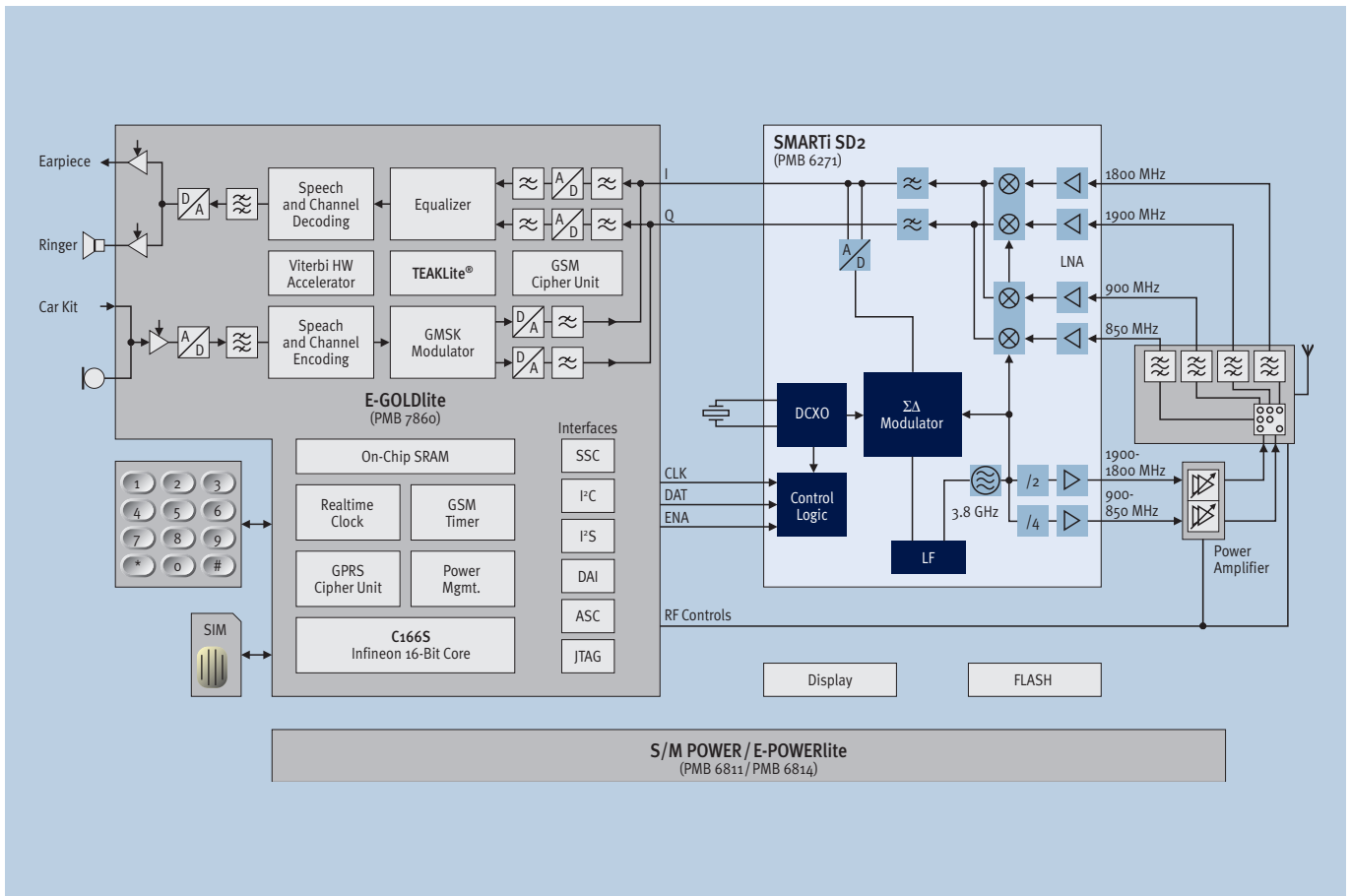

Note: TEAKLite® is a registered trademark of ParthusCeva, Inc.

How to reach us:  
<http://www.infineon.com>

Published by  
**Infinion Technologies AG**  
 St.-Martin-Strasse 53  
 81669 München

© Infineon Technologies AG 2004.  
 All Rights Reserved.

Template: pb\_w\_tmplt.fm/2

### Attention please!

The information herein is given to describe certain components and shall not be considered as a guarantee of characteristics. Terms of delivery and rights to technical change reserved.

We hereby disclaim any and all warranties, including but not limited to warranties of non-infringement, regarding circuits, descriptions and charts stated herein.

### Information

For further information on technology, delivery terms and conditions and prices please contact your nearest Infineon Technologies Office.

### Warnings

Due to technical requirements components may contain dangerous substances. For information on the types in question please contact your nearest Infineon Technologies Office.

Infinion Technologies Components may only be used in life-support devices or systems with the express written approval of Infineon Technologies, if a failure of such components can reasonably be expected to cause the failure of that life-support device or system, or to affect the safety or effectiveness of that device or system. Life support devices or systems are intended to be implanted in the human body, or to support and/or maintain and sustain and/or protect human life. If they fail, it is reasonable to assume that the health of the user or other persons may be endangered.

Ordering No. B134-H8550-XX-7600  
 Printed in Germany  
 PS 01052. nb